

# K4SD

**Kawasaki Z750 '04- 06**  
**Kawasaki Z1000 '03- 06**

## LEFT SIDE KIT

ID	Description	Cat.no.	Pcs
1	Dural. adapter	545	1
2	Bolt M12x25	860	1
3	Bolt M10x140	953	1
4	Alu. cylinder 56mm	202	1
5	Nut M10	814	1
6	Plastic cap	X4	1
7	Alu. cylinder 40mm	DV12	1
8	Washer M10 (spring)	801	1
9	Bolt M10x65	943	1
10	3M tape		1
11	Bolt M8x25	815	2
12	Washer M8	802	2
13	Adapter SLD	537	1
14	Threaded rod AL20(M12)x377x30x30		1

## RIGHT SIDE KIT

ID	Description	Cat.no.	Pcs
1	Dural. adapter	546	1
2	Bolt M12x25	860	1
3	Bolt M10x140	953	1
4	Alu. cylinder 56mm	202	1
5	Nut M10	814	1
6	Plastic cap	X4	1
7	Alu. cylinder 40mm	DV12	1
8	Washer M10 (spring)	801	1
9	Bolt M10x65	943	1
10	3M tape		1
11	Bolt M8x25	815	2
12	Washer M8	802	2
13	Adapter SLD	537	1

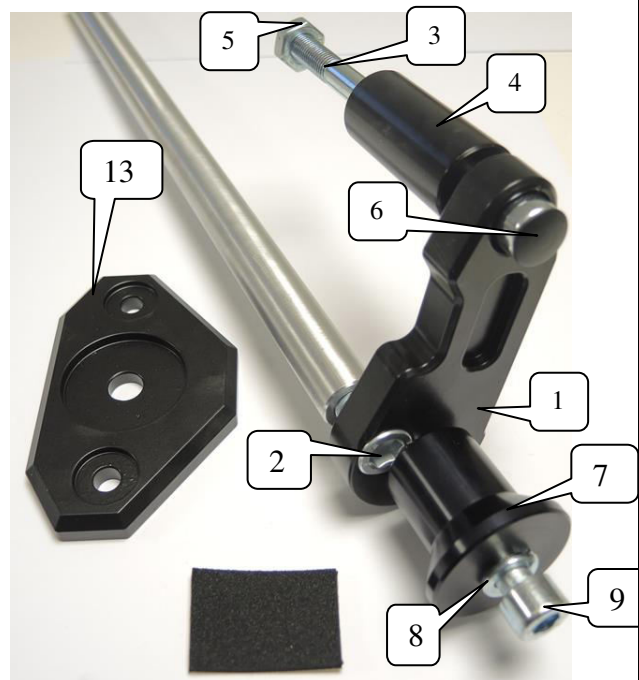
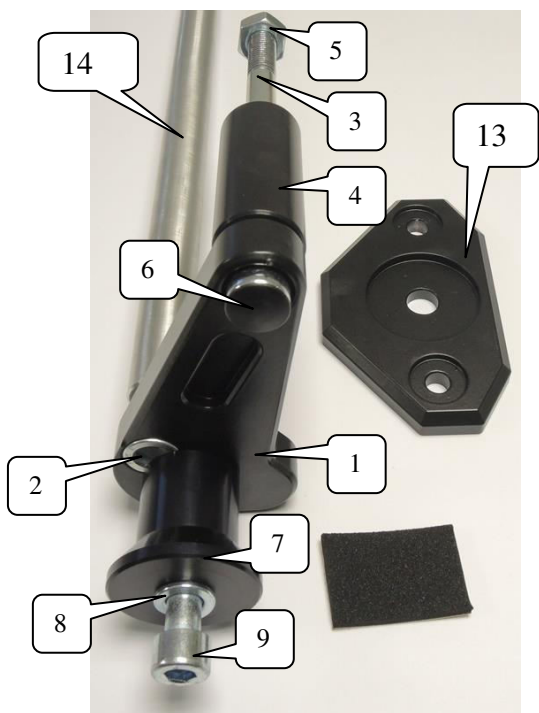

## INSTRUCTIONS

- 1) Unbolt original bolt from the frame
- 2) Stick 3M tape on the frame of motorcycle.
- 3) Assembly dural. adapter according to the pictures on page one.
- 4) Fit this kit on the frame of motorcycle.
- 5) Put rod through the engine space and fit it using bolt ID2.
- 6) Repeat same proces on the other side.
- 7) Tighten whole kit.
- 8) Put washer ID8, adapter ID13 and cylinder ID7 on the bolt. Mount this kit into the adapter ID1.
- 9) Fit slider using bolts ID11 and washer ID12.

**We recommend to use the glue on all threads (medium strong).**

Illustrative pictures (the same kit, different protector)

